

## Bells and Accessories for Level Monitoring



Bell OGL



Bell OGL-GU



Small air compressor in plastic casing

Order reference	Description	Weight (in g)	Part No.
	<b>Wet bells</b>		
OGL-8	Open wet bell with screw connection for PL-8/6	250	260530
OGL Installation kit	Installation kit for OGL-8, stainless steel, screw tube clamp and Stockschraube	150	282198
OGL-8 GU	Open wet bell (gray cast iron with stainless steel chain) with screw connection for PL-8/6, chain length 2,9 m	1100	290117
	<b>Pneumatic tube (PL)</b> PL-8/6 – 8 mm outer-ø, 6 mm inner-ø PL-6/4 – 6 mm outer-ø, 4 mm inner-ø		
PL-8/6, 10 m	10m rope PL-8/6	225	260554
PL-8/6, 20 m	20m rope PL-8/6	450	260561
PL-8/6, 1 m	Length > 20 m, each m (max. length per rope 100 m)	23	260578
PL-6/4, 1 m	Pneumatic tube PL-6 (price / m)	20	260585
	<b>Screw connections</b>		
Screw connection 1/8"	Screw connection 1/8" for OGL-8 GU / GGL-8	20	260592
R-SCH	Reducing screw connector for PL from PL-8/6 to PL-6/4	22	260615
T-ST 6	T-plug connector für PL-6/4 for aeration	11	260622
T-SCH 8	T-screw connector for PL-8/6 for aeration	14	260639
	<b>Small compressors</b>		
Rena-Air 100	for aeration, incl. check and security valve with T-screw connector for PL-8/6 (120 L/h; 150 mb; 3W; 230 V AC IP X4), e.g. usable with open wet bells	315	260646
Rena-Air 100 in casing	for aeration, incl. check and security valve with T-screw connector for PL-8/6 (120 L/h; 150 mb; 3W; 230 V AC IP X4), e.g. usable with open wet bells	720	260653

## Bell Dimensions

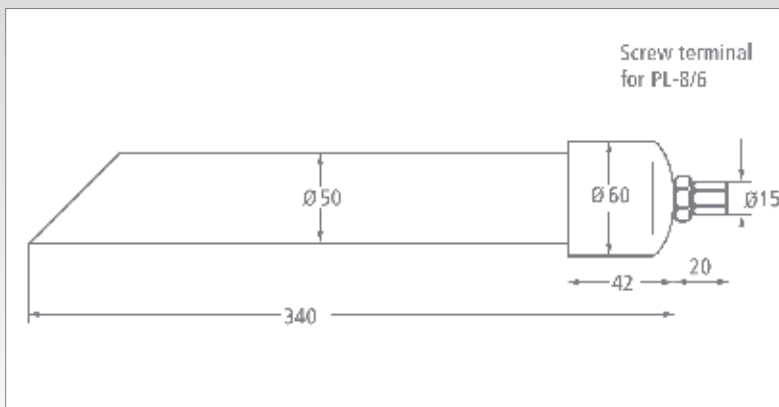

Bell OGL

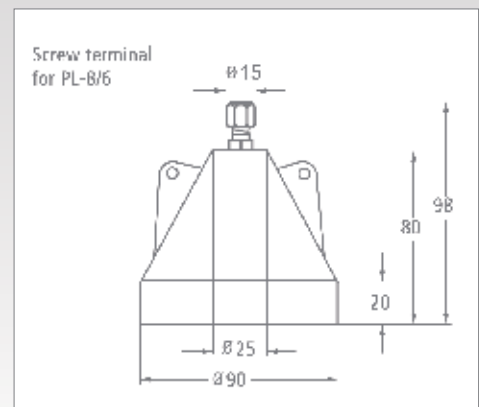

Bell OGL – GU